



10623 Roselle Street, San Diego, CA 92121 • (858) 550-9559 • Fax (858) 550-7322
contactus@accessio.com • www.accessio.com

**ISOLATED DIGITAL
INPUT / RELAY OUTPUT
BOARD
MODEL 104-II32-4RO
USER MANUAL**

File: M104-II32-4RO.B1h

Notice

The information in this document is provided for reference only. ACCES does not assume any liability arising out of the application or use of the information or products described herein. This document may contain or reference information and products protected by copyrights or patents and does not convey any license under the patent rights of ACCES, nor the rights of others.

IBM PC, PC/XT, and PC/AT are registered trademarks of the International Business Machines Corporation.

Printed in USA. Copyright 2005 by ACCES I/O Products, Inc. 10623 Roselle Street, San Diego, CA 92121. All rights reserved.

WARNING!!

ALWAYS CONNECT AND DISCONNECT YOUR FIELD CABLING WITH THE COMPUTER POWER OFF. ALWAYS TURN COMPUTER POWER OFF BEFORE INSTALLING A BOARD. CONNECTING AND DISCONNECTING CABLES, OR INSTALLING BOARDS INTO A SYSTEM WITH THE COMPUTER OR FIELD POWER ON MAY CAUSE DAMAGE TO THE I/O BOARD AND WILL VOID ALL WARRANTIES, IMPLIED OR EXPRESSED.

Warranty

Prior to shipment, ACCES equipment is thoroughly inspected and tested to applicable specifications. However, should equipment failure occur, ACCES assures its customers that prompt service and support will be available. All equipment originally manufactured by ACCES which is found to be defective will be repaired or replaced subject to the following considerations.

Terms and Conditions

If a unit is suspected of failure, contact ACCES' Customer Service department. Be prepared to give the unit model number, serial number, and a description of the failure symptom(s). We may suggest some simple tests to confirm the failure. We will assign a Return Material Authorization (RMA) number which must appear on the outer label of the return package. All units/components should be properly packed for handling and returned with freight prepaid to the ACCES designated Service Center, and will be returned to the customer's/user's site freight prepaid and invoiced.

Coverage

First Three Years: Returned unit/part will be repaired and/or replaced at ACCES option with no charge for labor or parts not excluded by warranty. Warranty commences with equipment shipment.

Following Years: Throughout your equipment's lifetime, ACCES stands ready to provide on-site or in-plant service at reasonable rates similar to those of other manufacturers in the industry.

Equipment Not Manufactured by ACCES

Equipment provided but not manufactured by ACCES is warranted and will be repaired according to the terms and conditions of the respective equipment manufacturer's warranty.

General

Under this Warranty, liability of ACCES is limited to replacing, repairing or issuing credit (at ACCES discretion) for any products which are proved to be defective during the warranty period. In no case is ACCES liable for consequential or special damage arriving from use or misuse of our product. The customer is responsible for all charges caused by modifications or additions to ACCES equipment not approved in writing by ACCES or, if in ACCES opinion the equipment has been subjected to abnormal use. "Abnormal use" for purposes of this warranty is defined as any use to which the equipment is exposed other than that use specified or intended as evidenced by purchase or sales representation. Other than the above, no other warranty, expressed or implied, shall apply to any and all such equipment furnished or sold by ACCES.

TABLE OF CONTENTS

Chapter 1: FUNCTIONAL DESCRIPTION	5
Figure 1-1: BLOCK DIAGRAM	6
Figure 1-2: EXAMPLE OF ONE INPUT CIRCUIT	6
Chapter 2: INSTALLATION	7
Figure 2-1: PC/104 Key Information	8
Chapter 3: OPTION SELECTION	9
FILTER RESPONSE SWITCH	9
Figure 3-1: OPTION SELECTION MAP	10
ADDRESS SELECTION	11
Table 3-1: ADDRESS ASSIGNMENTS FOR COMPUTERS	11
Chapter 4: PROGRAMMING	13
Chapter 5: SOFTWARE	16
Chapter 6: CONNECTOR PIN ASSIGNMENTS	17
Table 6-1: Connector Pin Assignments P1	17
Table 6-2: Connector Pin Assignments P2	18

Chapter 1: FUNCTIONAL DESCRIPTION

The board provides isolated digital inputs with Change of State Detection and electromechanical relay output interfaced for PC/104 compatible computers. The board provides thirty two optically-isolated inputs for AC or DC control signals and four electromechanical relay outputs. The board occupies eight consecutive addresses in I/O space. Read and write operations are done on an 8-bit-byte oriented basis.

INPUTS

The isolated inputs can be driven by either AC or DC signals and are not polarity sensitive. Input signals are rectified by photocoupler diodes. A 1.8K-ohm resistor in series dissipates unused power. Standard 12/24 AC control transformer outputs can be accepted as well as DC voltages. The input voltage range is 3 to 31 volts (rms) for a "hi" or "1" reading. External resistors connected in series may be used to extend the input voltage range, however this will raise the input threshold. Consult with factory for available modified input ranges.

Each input circuit contains a switchable filter that has a 4.7 mS time constant. (Without filtering, the response is 10 uS.) The filter must be selected for AC inputs in order to eliminate the on/off response to AC. The filter is also valuable for use with slow DC input signals in a noisy environment. The filter may be switched out for DC inputs in order to obtain faster response. Filters are individually selected by jumpers. The filters are switched into the circuit when the jumpers are installed in position FLT0 to FLT31.

INTERRUPTS

When enabled by a software write, the board asserts an interrupt whenever any of the inputs changes state from high to low, or low to high. This is called Change-of-State (COS) detection. Once an interrupt has been generated and serviced, it must be cleared by a software write. The 32 inputs are enabled in 8 groups of 4 inputs each.

Interrupts are directed to IRQ levels #3 through #7, #9 through #12, #14 and #15 by jumper installation.

This board has been designed to allow for IRQ sharing. When a COS event happens the selected IRQ level comes out of tri-state for 1 uS during which the IRQ signal is 'low' for 750 nS then transitions to 'high' for 250nS. This event can be read back by a software read and cleared by a software write.

OUTPUTS

The electromechanical relay outputs are comprised of four FORM C SPDT outputs. The relays are all de-energized at power-on. Data to the relays is latched by a software write.

A fused +5V source is available on the 50 pin I/O connector for general purpose use. There are two (2) pins with this source, as well as two (2) Ground pins. A "polyfuse" will open the circuit if 0.5A is drawn for more than a moment, acting as a slow-blow type fuse. This fuse is resettable however, and once the source of excessive current is corrected, the fuse will reset. If no action is taken by the user, the fuse will open until it's element cools off, then the fuse will reset, and if the current is still at 0.5A, the fuse will open again.

13	GND	Ground
14	Vcc	+5 volts (fused)
15	Vcc	+5 volts (fused)
16	GND	Ground

Figure 1-1: BLOCK DIAGRAM

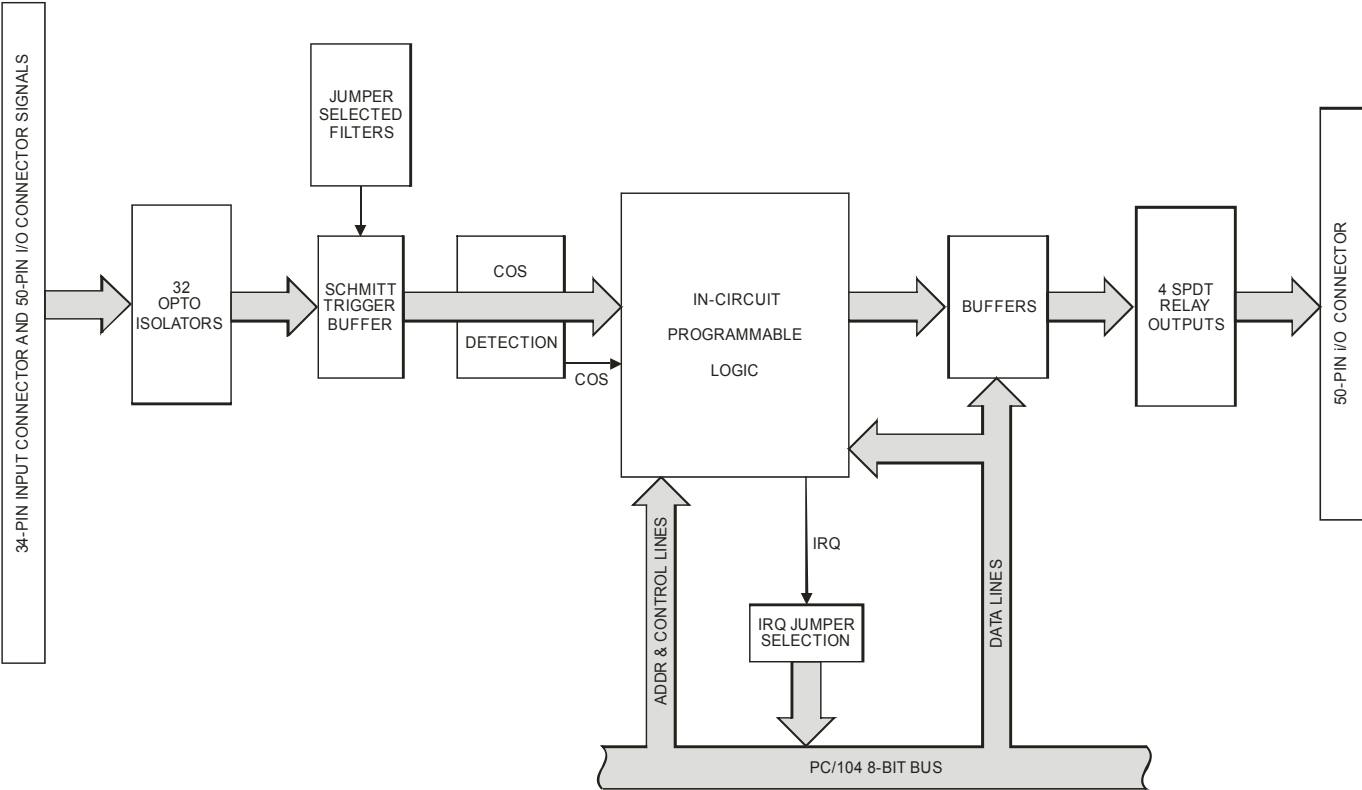
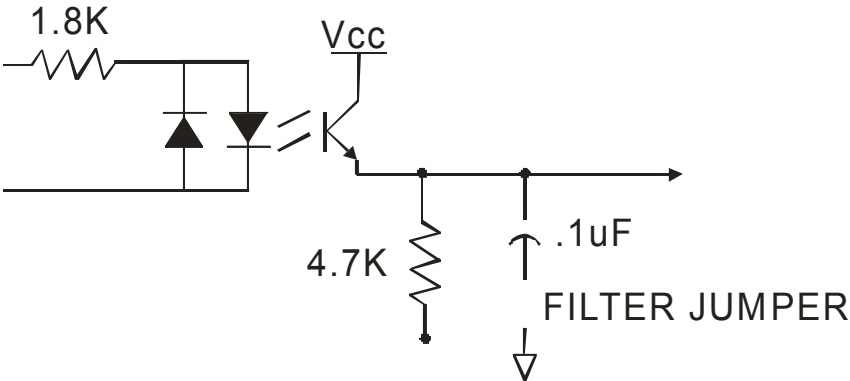

Figure 1-2: EXAMPLE OF ONE INPUT CIRCUIT



Chapter 2: INSTALLATION

A printed Quick-Start Guide (QSG) is packed with the board for your convenience. If you've already performed the steps from the QSG, you may find this chapter to be redundant and may skip forward to begin developing your application.

The software provided with this PC/104 Board is on CD and must be installed onto your hard disk prior to use. To do this, perform the following steps as appropriate for your operating system. Substitute the appropriate drive letter for your CD-ROM where you see d: in the examples below.

CD Installation

The following instructions assume the CD-ROM drive is drive "D". Please substitute the appropriate drive letter for your system as necessary.

DOS

1. Place the CD into your CD-ROM drive.
2. Type `D:\Enter` to change the active drive to the CD-ROM drive.
3. Type `INSTALL\Enter` to run the install program.
4. Follow the on-screen prompts to install the software for this board.

WINDOWS

1. Place the CD into your CD-ROM drive.
2. The system should automatically run the install program. If the install program does not run promptly, click START | RUN and type `D:\INSTALL`, click OK or press `Enter`.
3. Follow the on-screen prompts to install the software for this board.

LINUX

1. Please refer to linux.htm on the CD-ROM for information on installing under linux.

Installing the Hardware

Before installing the board, carefully read Chapter 3 and Chapter 4 of this manual and configure the board according to your requirements. The SETUP Program can be used to assist in configuring jumpers on the board. Be especially careful with Address Selection. If the addresses of two installed functions overlap, you will experience unpredictable computer behavior. To help avoid this problem, refer to the FINDBASE.EXE program installed from the CD. The setup program does not set the options on the board, these must be set by jumpers.

To Install the Board

1. Install jumpers for selected options and base address according to your application requirements, as mentioned above.
2. Remove power from the PC/104 stack.
3. Assemble standoff hardware for stacking and securing the boards.
4. Carefully plug the board onto the PC/104 connector on the CPU or onto the stack, ensuring proper alignment of the pins before completely seating the connectors together.
5. Install I/O cables onto the board's I/O connectors and proceed to secure the stack together or repeat steps 3-5 until all boards are installed using the selected mounting hardware.
6. Check that all connections in your PC/104 stack are correct and secure then power up the system.
7. Run one of the provided sample programs appropriate for your operating system that was installed from the CD to test and validate your installation.

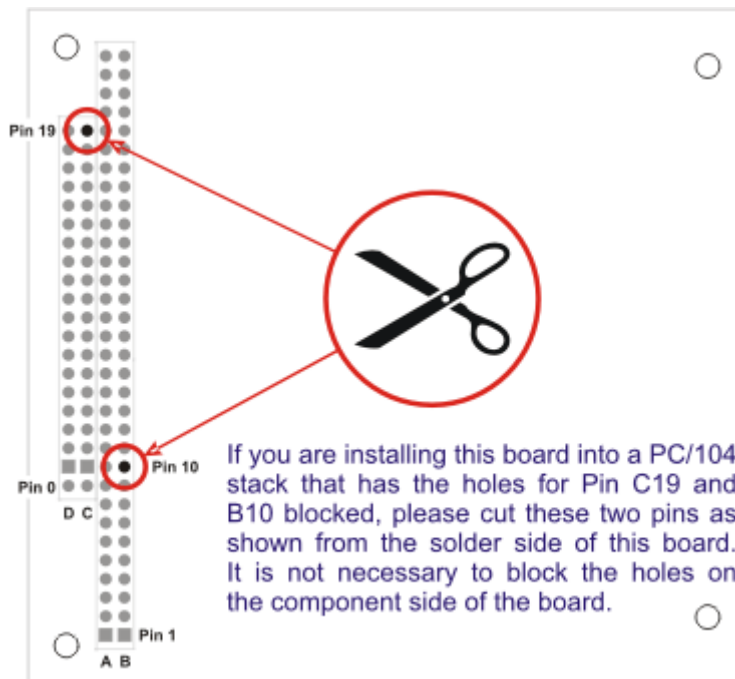

Figure 2-1: PC/104 Key Information

Chapter 3: OPTION SELECTION

FILTER RESPONSE SWITCH

Jumpers are used to select input filtering on a channel-by-channel basis. When jumper FLT0 is installed, filtering is introduced for input bit 0, FLT1 for bit 1, etc.

JUMPER SELECTION	Bit Filtered
FLT 0	IN00
FLT 1	IN01
FLT 2	IN02
FLT 3	IN03
FLT 4	IN04
FLT 5	IN05
FLT 6	IN06
FLT 7	IN07
FLT 8	IN08
FLT 9	IN09
FLT 10	IN10
FLT 11	IN11
FLT 12	IN12
FLT 13	IN13
FLT 14	IN14
FLT 15	IN15

JUMPER SELECTION	Bit Filtered
FLT 16	IN16
FLT 17	IN17
FLT 18	IN18
FLT 19	IN19
FLT 20	IN20
FLT 21	IN21
FLT 22	IN22
FLT 23	IN23
FLT 24	IN24
FLT 25	IN25
FLT 26	IN26
FLT 27	IN27
FLT 28	IN28
FLT 29	IN29
FLT 30	IN30
FLT 31	IN31

This filtering provides a slower response for DC signals as described previously and must be used when AC inputs are applied. If you believe an input may be electrically noisy, install the jumper to avoid false readings.

INTERRUPTS

Select the desired interrupt level by installing a jumper at one of the locations marked IRQxx. An interrupt is asserted by the board when an Isolated Digital Input bit changes state, if enabled in software. A full description of how to enable/disable and clear IRQs is described in the Programming section of this manual.

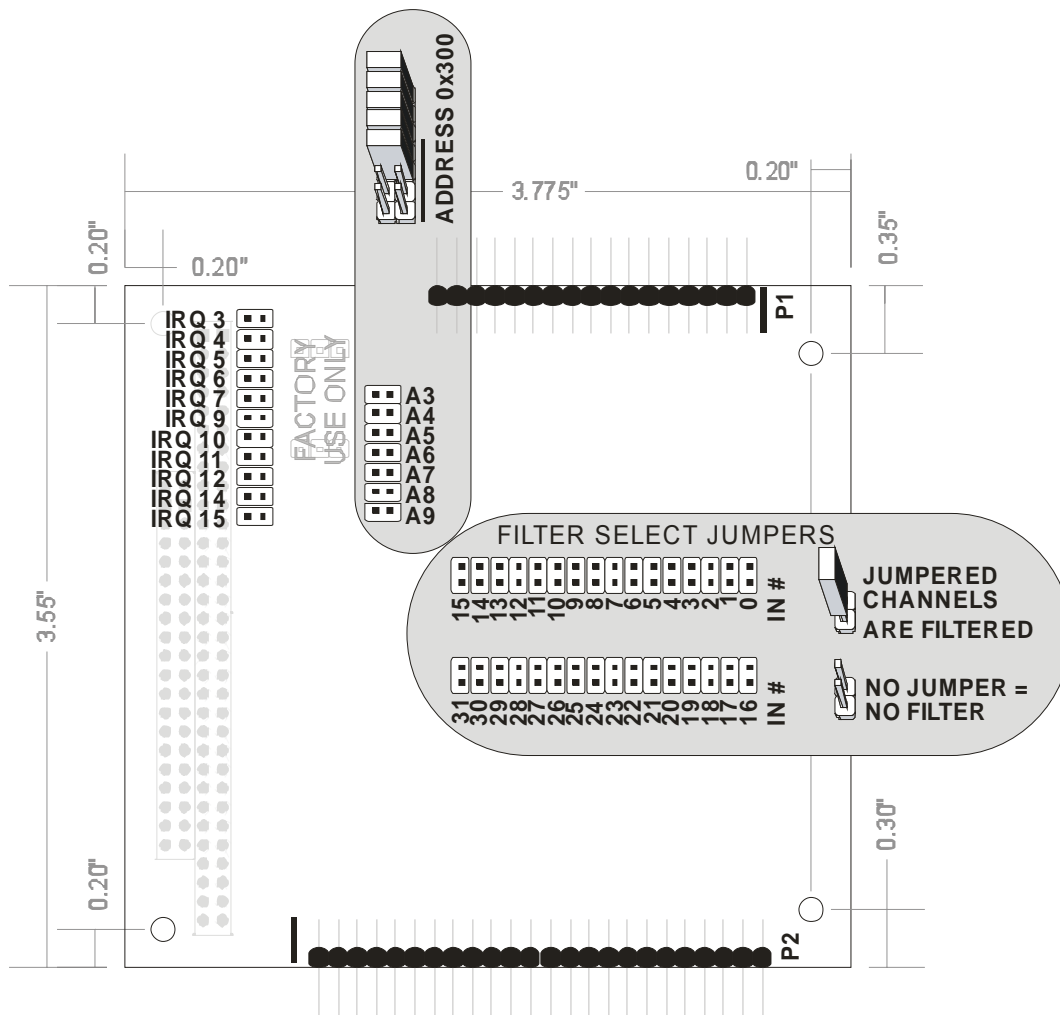

Figure 3-1: OPTION SELECTION MAP
(A2 not used)

ADDRESS SELECTION

This board occupies eight consecutive addresses in I/O space. The base or starting address can be selected anywhere within the I/O address range of 100-3FF, provided that it does not cause an overlap with other functions. If the addresses of two installed functions overlap, you will experience unpredictable computer behavior. The FINDBASE program supplied by ACCES will assist you in selecting a base address that will avoid this conflict.

Table 3-1: ADDRESS ASSIGNMENTS FOR COMPUTERS

HEX RANGE	USAGE
000-00F	8237 DMA Controller 1
020-021	8259 Interrupt
040-043	8253 Timer
060-06F	8042 Keyboard Controller
070-07F	CMOS RAM, NMI Mask Reg, RT Clock
080-09F	DMA Page Register
0A0-0BF	8259 Slave Interrupt Controller
0C0-0DF	8237 DMA Controller 2
0F0-0F1	Math Coprocessor
0F8-0FF	Math Coprocessor
170-177	Fixed Disk Controller 2
1F0-1F8	Fixed Disk Controller 1
200-207	Game Port
238-23B	Bus Mouse
23C-23F	Alt. Bus Mouse
278-27F	Parallel Printer
2B0-2BF	EGA
2C0-2CF	EGA
2D0-2DF	EGA
2E0-2E7	GPIB (AT)
2E8-2EF	Serial Port
2F8-2FF	Serial Port
300-30F	reserved
310-31F	reserved
320-32F	Hard Disk (XT)
370-377	Floppy Controller 2
378-37F	Parallel Printer
380-38F	SDLC
3A0-3AF	SDLC
3B0-3BB	MDA
3BC-3BF	Parallel Printer
3C0-3CF	VGA EGA
3D0-3DF	CGA
3E8-3EF	Serial Port
3F0-3F7	Floppy Controller 1
3F8-3FF	Serial Port

The board's base address is set up by JUMPERS. Those jumpers control address bits A3 through A9. (Lines A2, A1 and A0 are used on the board to control individual registers. How these three lines are used is described in the Programming section of this manual.)

To determine how to set these JUMPERS for a desired hex-code address, refer to the SETUP program provided with the board. If you prefer to determine proper jumper settings yourself, first convert the hex-code address to binary form. Then, for each "0", install corresponding jumpers and for each "1", remove the corresponding jumper.

The following example illustrates jumper selection corresponding to hex 300 (or binary 11 0000 0xxx). The "xxx" represents address lines A2, A1, and A0 used on the board to select individual registers as described in the Programming section of this manual.

Base Address in Hex Code	3		0				0
Conversion Factors	2	1	8	4	2	1	8
Binary Representation	1	1	0	0	0	0	0
Jumper Legend	A9	A8	A7	A6	A5	A4	A3
Addr. Line Controlled	A9	A8	A7	A6	A5	A4	A3
Jumper Selection	OFF	OFF	ON	ON	ON	ON	ON

Carefully review the address selection reference table on the preceding page before selecting the board address. If the addresses of two installed functions overlap, you will experience unpredictable computer behavior.

Chapter 4: PROGRAMMING

The board occupies eight consecutive addresses in PC I/O space. The base or starting address is selected during installation and will fall on an eight-byte boundary. The boards read and write functions as follows:

I/O Address	Read	Write
Base + 0	Read Isolated Inputs 00 - 07	Write Relay Outputs 0 - 3
Base + 1	Read Isolated Inputs 08 - 15	unused
Base + 2	Read Isolated Inputs 16 - 23	unused
Base + 3	Read Isolated Inputs 24 - 31	unused
Base + 4	unused	Dis/Enable IRQ (00/0F)
Base + 5	Read COS Status Register	Clear Interrupt
Base + 6	unused	unused
Base + 7	unused	unused

ISOLATED DIGITAL INPUTS

Isolated digital input states are read as a single byte from the port. Each of the eight bits within the byte corresponds to a particular digital input. A "1" signifies that the input is energized, (on/high) and a "0" signifies that the input is de-energized (off/low).

Read at Base +0

Bit Position	D7	D6	D5	D4	D3	D2	D1	D0
Iso Digital Input	IIN07	IIN06	IIN05	IIN04	IIN03	IIN02	IIN01	IIN00

Read at Base +1

Bit Position	D7	D6	D5	D4	D3	D2	D1	D0
Iso Digital Input	IIN15	IIN14	IIN13	IIN12	IIN11	IIN10	IIN09	IIN08

Read at Base +2

Bit Position	D7	D6	D5	D4	D3	D2	D1	D0
Iso Digital Input	IIN23	IIN22	IIN21	IIN20	IIN19	IIN18	IIN17	IIN16

Read at Base +3

Bit Position	D7	D6	D5	D4	D3	D2	D1	D0
Iso Digital Input	IIN31	IIN30	IIN29	IIN28	IIN27	IIN26	IIN25	IIN24

The board response to inputs is rated at 10 uS. Sometimes it is necessary to slow down that response to accommodate AC inputs or in noisy environments. Hardware installation of JUMPERS to implement filtering are provided.

COS (change-of-state)

The board supports interrupts on change of state of isolated digital inputs. Enabling the COS feature is controlled by writing to base address +4. The COS feature is enabled and read back in 8 groups of 4 inputs according to the table below. Data is written to all eight COS groups as a single byte. Each bit within the byte controls a specific COS group. A "1" enables the corresponding group and a "0" disables it.

Write to Base +4

Bit Position	D7	D6	D5	D4	D3	D2	D1	D0
COS Group	H	G	F	E	D	C	B	A

COS GROUP	ISOLATED INPUT	COS GROUP	ISOLATED INPUT
A	IIN00	E	IIN16
	IIN01		IIN17
	IIN02		IIN18
	IIN03		IIN19
B	IIN04	F	IIN20
	IIN05		IIN21
	IIN06		IIN22
	IIN07		IIN23
C	IIN08	G	IIN24
	IIN09		IIN25
	IIN10		IIN26
	IIN11		IIN27
D	IIN12	H	IIN28
	IIN13		IIN29
	IIN14		IIN30
	IIN15		IIN31

Reading the COS Status Register is accomplished by a read to base +5. This status register is read as a single byte. Each of the eight bits corresponds to a particular COS group in the same manner as the enabling byte. A "1" signifies that a COS has occurred on one of the four associating isolated inputs, a "0" signifies that a COS has not occurred.

Clearing IRQs as well as the COS Status Register is accomplished by writing any value to base address +5. This clears all COS groups together.

RELAY OUTPUTS

At power-up, all relays are initialized in the de-energized state. The relay outputs are controlled by writing to base address. Data is written to all four relays as a single byte. Each of the first four bits within the byte controls a specific relay, the last four bits do not control anything. A "0" energizes the corresponding relay and a "1" turns it off.

Write to Base +0

Bit Position	D7	D6	D5	D4	D3	D2	D1	D0
Relay Controlled	N/A	N/A	N/A	N/A	OUT3	OUT2	OUT1	OUT0

For example, if bit D2 is turned on by writing hex DF to the base address, then the relay that is controlled by OUT2 is energized closing the associated normally-open contacts. All other relays would be de-energized and their normally-closed contacts would be closed.

Chapter 5: SOFTWARE

Utility software provided on CD with the board include the base address locator, an illustrated setup program and a sample program. The sample program sequentially turns on and off each relay (walking bit). After each relay is turned on, the opto-isolated inputs are read, and the data is displayed.

FINDBASE: DOS Program locates active and available port addresses.

SETUP: Windows Board Setup Program for jumpers on the board.

The sample programs are in forms suitable for use with QuickBASIC, C, and Pascal.

CSAMPLES: SAMPLE1 This sample program sequentially turns on all relay control bits and sequentially turns them off (walking bit). Each time it sets a new bit, both the relay status and the isolated input are read and the data displayed. This demonstrates how to read and write to a port.

PSAMPLES: SAMPLE1 Same sample in Pascal.

Chapter 6: CONNECTOR PIN ASSIGNMENTS

Isolated Inputs are connected to the board via a 34-pin HEADER type connector named P1. The mating connector is an IDC type with 0.1 inch centers or equivalent.

The wiring may be directly from the signal sources or may be on ribbon cable from screw terminal accessory boards. Pin assignments are as follows:

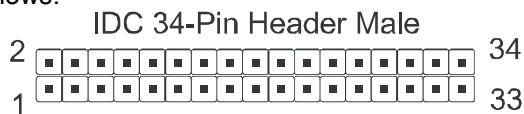

PIN	NAME	FUNCTION
1	IIN00 A	Isolated Input 00 A
2	IIN00 B	Isolated Input 00 B
3	IIN01 A	Isolated Input 01 A
4	IIN01 B	Isolated Input 01 B
5	IIN02 A	Isolated Input 02 A
6	IIN02 B	Isolated Input 02 B
7	IIN03 A	Isolated Input 03 A
8	IIN03 B	Isolated Input 03 B
9	IIN04 A	Isolated Input 04 A
10	IIN04 B	Isolated Input 04 B
11	IIN05 A	Isolated Input 05 A
12	IIN05 B	Isolated Input 05 B
13	IIN06 A	Isolated Input 06 A
14	IIN06 B	Isolated Input 06 B
15	IIN07 A	Isolated Input 07 A
16	IIN07 B	Isolated Input 07 B
17		
18		
19	IIN08 A	Isolated Input 08 A
20	IIN08 B	Isolated Input 08 B
21	IIN09 A	Isolated Input 09 A
22	IIN09 B	Isolated Input 09 B
23	IIN10 A	Isolated Input 10 A
24	IIN10 B	Isolated Input 10 B
25	IIN11 A	Isolated Input 11 A
26	IIN11 B	Isolated Input 11 B
27	IIN12 A	Isolated Input 12 A
28	IIN12 B	Isolated Input 12 B
29	IIN13 A	Isolated Input 13 A
30	IIN13 B	Isolated Input 13 B
31	IIN14 A	Isolated Input 14 A
32	IIN14 B	Isolated Input 14 B
33	IIN15 A	Isolated Input 15 A
34	IIN15 B	Isolated Input 15 B

Table 6-1: Connector Pin Assignments P1

Relay outputs are connected to the board via a 50-pin HEADER type connector named P2. The mating connector is an IDC type with 0.1 inch centers or equivalent.



PIN	NAME	FUNCTION	PIN	NAME	FUNCTION
1	OUT0-NO	Bit 7 Relay, Normally-Open Contact	26	IIN27 B	Isolated Input 27 B
2	OUT0-C	Bit 7 Relay Common	27	IIN26 A	Isolated Input 26 A
3	OUT0-NC	Bit 7 Relay, Normally-Closed Contact	28	IIN26 B	Isolated Input 26 B
4	OUT1-NO	Bit 6 Relay, Normally-Open Contact	29	IIN25 A	Isolated Input 25 A
5	OUT1-C	Bit 6 Relay Common	30	IIN25 B	Isolated Input 25 B
6	OUT1-NC	Bit 6 Relay, Normally-Closed Contact	31	IIN24 A	Isolated Input 24 A
7	OUT2-NO	Bit 5 Relay, Normally-Open Contact	32	IIN24 B	Isolated Input 24 B
8	OUT2-C	Bit 5 Relay Common	33		
9	OUT2-NC	Bit 5 Relay, Normally-Closed Contact	34		
10	OUT3-NO	Bit 4 Relay, Normally-Open Contact	35	IIN23 A	Isolated Input 23 A
11	OUT3-C	Bit 4 Relay Common	36	IIN23 B	Isolated Input 23 B
12	OUT3-NC	Bit 4 Relay, Normally-Closed Contact	37	IIN22 A	Isolated Input 22 A
13	GND	Ground	38	IIN22 B	Isolated Input 22 B
14	Vcc	+5 volts (fused)	39	IIN21 A	Isolated Input 21 A
15	Vcc	+5 volts (fused)	40	IIN21 B	Isolated Input 21 B
16	GND	Ground	41	IIN20 A	Isolated Input 20 A
17	IIN31 A	Isolated Input 31 A	42	IIN20 B	Isolated Input 20 B
18	IIN31 B	Isolated Input 31 B	43	IIN19 A	Isolated Input 19 A
19	IIN30 A	Isolated Input 30 A	44	IIN19 B	Isolated Input 19 B
20	IIN30 B	Isolated Input 30 B	45	IIN18 A	Isolated Input 18 A
21	IIN29 A	Isolated Input 29 A	46	IIN18 B	Isolated Input 18 B
22	IIN29 B	Isolated Input 29 B	47	IIN17 A	Isolated Input 17 A
23	IIN28 A	Isolated Input 28 A	48	IIN17 B	Isolated Input 17 B
24	IIN28 B	Isolated Input 28 B	49	IIN16 A	Isolated Input 16 A
25	IIN27 A	Isolated Input 27 A	50	IIN16 B	Isolated Input 16 B

Table 6-2: Connector Pin Assignments P2

Chapter 7: SPECIFICATIONS

ISOLATED INPUTS

Number of inputs:	Thirty two
Type	Non-polarized, optically isolated from each other and from the computer. (CMOS compatible)
Voltage Range:	3 to 31 DC or AC Rms (40 to 10000 Hz)
Isolation:	500V *(see note)
Input Resistance:	1.8K ohms in series with opto-coupler (two LEDs)
Response Time:	4.7 mSec w/filter, 10 uSec w/o filter (typical)
Interrupts:	Software controlled with jumper IRQ selection

RELAY OUTPUTS

Number of outputs:	Four SPDT form C
Contact Type:	Single crossbar; Ag with Au clad
Rated Load AC:	0.5A at 125VAC (62.5 VA max)
Rated Load DC:	1A max at 24VDC (60 W max)
Max. Switching Voltage:	125 VAC, 60 VDC
Max. Switching Current:	1 A
Contact Resistance:	100 mΩ maximum
Contact Life, mechanical:	5 million operations minimum
Operating Time:	5 milliseconds maximum
Release Time:	5 milliseconds maximum

INTERRUPTS: Interrupts are generated when isolated inputs change state if enabled by software.

POWER REQUIRED: +5VDC @ 150 mA (all relays ON)

ENVIRONMENTAL

Operating Temp:	0° to +70°C
Weight:	Approximately 3.02 oz.

*Notes on Isolation: Opto-Isolators and connectors are rated for at least 500V channel-to-channel and channel-to-ground. Isolation voltage breakdowns will vary and are affected by factors like cabling, spacing of pins, spacing between traces on the PCB, humidity, dust and other environmental factors. This is a safety issue so a careful approach is required. For CE certification, isolation was specified at 40V AC and 60V DC. The design intention was to eliminate the influence of common mode. Use proper wiring techniques to minimize voltage between channels and to ground. For example, when working with AC voltages do not connect the hot side of the line to an input. Tolerance of higher isolation voltage can be obtained on request by applying a conformal coating to the board.

Customer Comments

If you experience any problems with this manual or just want to give us some feedback, please email us at: ***manuals@acesio.com***. Please detail any errors you find and include your mailing address so that we can send you any manual updates.



10623 Roselle Street, San Diego CA 92121

Tel. (858)550-9559 FAX (858)550-7322

www.acesio.com